



CUTLER Repaving Inc.

Creators of the Single Machine Repaving Process

HOT IN-PLACE RECYCLING (REPAVING) TECHNICAL GUIDELINES

DESCRIPTION

This work shall consist of rehabilitating the surface layer of existing asphalt pavement. Rehabilitation shall be accomplished with specially designed equipment in a simultaneous multistep process of heating, scarifying, applying an asphalt recycling agent and thoroughly remixing and reshaping the old asphalt surface, and then placing an overlay of new hot mix asphalt in compliance with the lines, grades, thickness and typical cross sections shown on the plans.

NOTE

This work shall be performed with a single machine that heats, scarifies, recycles and spreads new asphalt hot mix, all in one continuous pass. Additional preheaters may be utilized to achieve specified depth and temperature. This process is defined as REPAVING in the *Basic Asphalt Recycling Manual*, published by the Asphalt Recycling and Reclaiming Association.



CONSTRUCTION METHODS

- ▶ The pavement to be treated shall be cleaned of trash, debris, earth or other deleterious substances present in sufficient quantity to interfere with the work to be performed.
- ▶ Overhanging trees must be trimmed to a height of 14 feet for clearance.
- ▶ The heating shall be sufficient to soften the pavement to the extent that it can be scarified to the depth specified. Due to the varying properties of the existing asphalt pavement, depth of the scarification material may be varied, if requested by the Engineer. Heating shall be done in a manner that will assure uniform softening and will not char the asphalt. Additional preheaters may be used to achieve design depths of 1½ to 2 inches on highway pavements.
- ▶ The Contractor shall be responsible for protecting the area adjacent to the work from heat damage. If damage occurs, the Contractor shall replace all damaged areas, landscape, curb, parked vehicles, etc. at no cost to the Agency.
- ▶ To provide a welded longitudinal joint, the standing edge of the adjoining asphalt pavement shall be fully heated to a width at least 2 inches beyond the width to be scarified and recycled.
- ▶ Immediately following heating, the pavement surface shall be scarified to the specified depth. The scarified material shall have a temperature between 225° F. and 265° F. unless otherwise requested by the Engineer. The material shall be leveled, mixed and treated with a recycling agent. The application rate shall be as shown on the plans, special provisions or as requested by the Engineer. Application rate for the recycling agent may be adjusted as necessary to maintain a uniform mixture.
- ▶ The reclaimed material shall be gathered by a leveling device and spread to a uniform depth over the width being processed. After it is placed and while it still has a residual temperature of at least 190° F., a layer of new HMA conforming to the job mix formula shall be placed over it. The application rate of new material shall be sufficient to provide the required pavement thickness.

WEATHER CONDITIONS

This work shall not be done when it is raining or if there is a threat of rain. The ambient temperature shall be at least 50° F. and rising and the application shall cease when the temperature reaches 55° F. and falling.

MEASUREMENT AND PAYMENT

- ▶ Pavement Recycling will be measured and paid for by the square yard completed in place.
- ▶ Asphalt Recycling Agent will be measured and paid for by the gallon of actual material used in place.
- ▶ Hot Mix Asphalt (HMA) will be measured and paid for by the ton used in place.



PRELIMINARY INVESTIGATION AND TESTING

CORING INFORMATION

Coring will be done by the Agency at a frequency to assure the pavement is in a condition suitable to HIR. Analysis should include total thickness, layer thickness, condition of asphalt, gradation and binder content, viscosity and penetration of existing asphalt, and presence of paving fabric. Core samples shall be taken at random locations across the width and length of the pavement.

MATERIALS

ASPHALT RECYCLING AGENT

Asphalt Recycling Agent used to restore the existing pavement shall be approved by the Engineer prior to use.

HOT MIX ASPHALT (HMA)

- ▶ HMA used as the surface course shall meet the requirements of Agency for hot mix asphalt (HMA), asphalt rubber (AR), asphalt friction course (AFC), asphalt rubber friction course (ARFC), warm mix (WM), or stone matrix asphalt (SMA).
- ▶ This material will be placed on top of the recycled layer in a simultaneous operation with a single piece of equipment.

MATERIAL TESTING

HMA Mix Design

Once the Agency selects the surface type of HMA, a mix design shall be submitted and approved by the Agency prior to use.

TESTING

COMPLIANCE

New HMA shall be sampled (by others) prior to delivery of the material into the receiving hopper of the Repaver and tested (by others) for compliance to the approved mix design, in accordance with Agency methods. The frequency of sampling and testing will be determined by the Agency. If the new HMA material is non-compliant the repaving shall be stopped until a resolution can be determined.

DENSITY

A nuclear density gauge shall be placed (by others) near the center of the hot mat and the position marked for future reference. Nuclear gauge reading (without mineral filler) shall be taken after each pass of the roller. Rolling shall continue until the maximum density is achieved. Others may check the pattern at a frequency determined by the Agency to assure maximum density is achieved. Rolling patterns shall be adjusted as directed by the Engineer as density results are evaluated.

THICKNESS

Thickness testing, scarification depth and asphalt overlay thickness can be verified by utilizing a depth probe behind the Paving Screed.

POST PROJECT TESTING (OPTIONAL)

Total thickness of the combined HMA layer and the recycled layer can be determined by coring.

SMOOTHNESS

IRI may be measured and compared to Agency Specifications. Bonus or penalties may apply.

EQUIPMENT

The Contractor shall specify, in the bid proposal, the type of equipment intended for use. The equipment shall be on the project in operating condition a minimum of two days before beginning operations to allow evaluation by the Engineer. The Engineer reserves the right to reject equipment deemed not suitable for the intended purpose, at no additional cost to the Agency.

THE RECYCLING EQUIPMENT SHALL MEET THE FOLLOWING MINIMUM REQUIREMENTS:

REPAVER

The equipment for this work shall be a self-contained, self-propelled, automated unit capable of heating, scarifying, mixing, redistributing and leveling the existing asphalt pavement to the specified depth, all in a single pass.

It shall have a means of automatically applying an asphalt recycling agent at a uniform rate. It shall be capable of applying a new HMA layer over the hot, partially compacted recycled mixture.

CONVEYING SYSTEM

Shall consist of a receiving hopper and conveying system to collect and transport new HMA material to the finishing unit.

HEATING UNIT(S)

This unit shall be hooded to prevent damage to adjacent property, including trees and shrubs. It shall be capable of heating the pavement surface to a temperature high enough (375°– 400° F.) to allow scarification to the required depth without breaking aggregate particles or charring the pavement surface.

SCARIFYING UNITS

The scarifiers shall be able to penetrate the pavement surface to a depth shown, up to a maximum of one inch in one pass. Scarifiers shall be equipped with separate, automatic height adjustments which allow clearance over manholes and other obstructions.

RECYCLING AGENT APPLICATOR

This system shall automatically add recycling agent to the scarified material at a uniform rate as shown on the plans, special provisions or as requested by the Engineer. The application rate shall be synchronized with the machine's forward speed to maintain a tolerance within 5% of the specified rate.

RECYCLING UNIT

A system that mixes, distributes and levels the scarified material over the width processed to produce a uniform cross-section of recycled material.

FINISHING UNIT

This unit shall have automatic screed controls to produce a surface conforming to that shown on the plans. The unit shall be capable of producing a uniform slope, grade and texture.

ROLLERS

Shall be capable of achieving specified density and smoothness requirements.



REPAVER SIDE VIEW

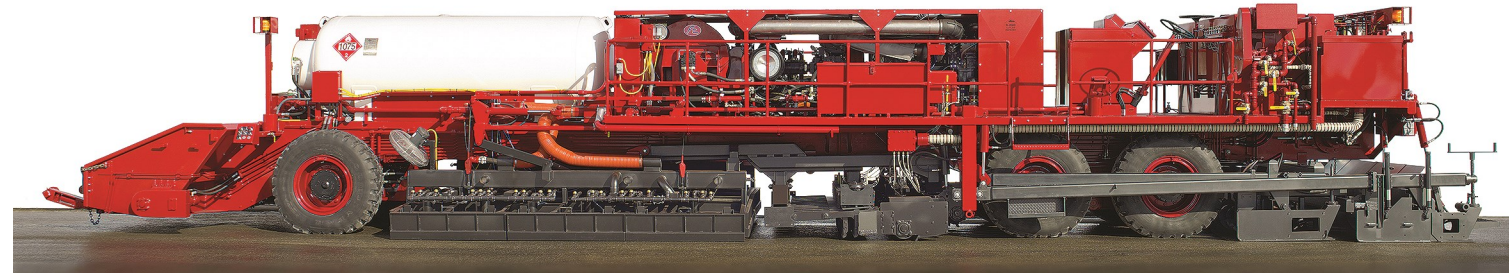

Receiving Hopper for New HMA Heating Unit Scarifying Units Recycling Agent Applicator Recycling Unit Finishing Unit

REPAVER COMPONENTS TOPSIDE VIEW

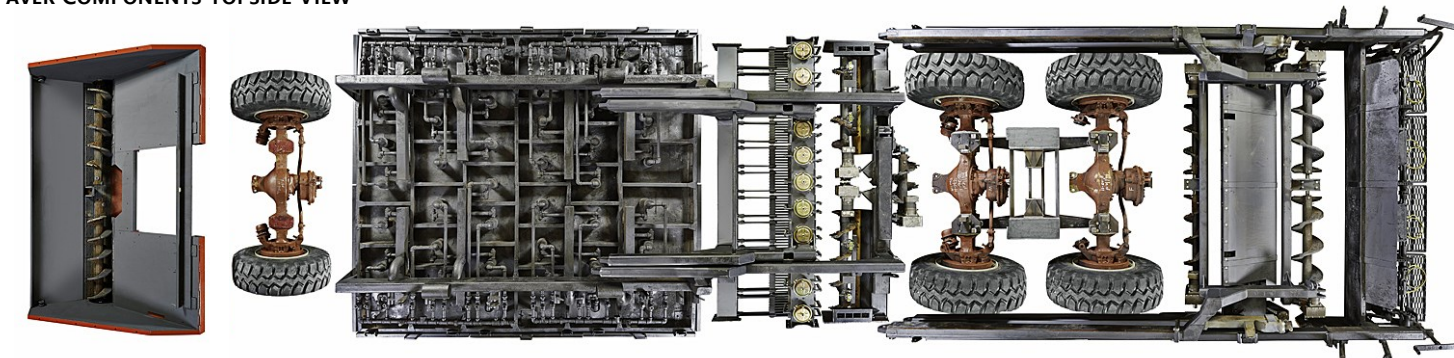

Receiving Hopper for New HMA Heating Unit Scarifying Units Recycling Agent Applicator Recycling Unit Finishing Unit

REPAVER COMPONENTS UNDERSIDE VIEW

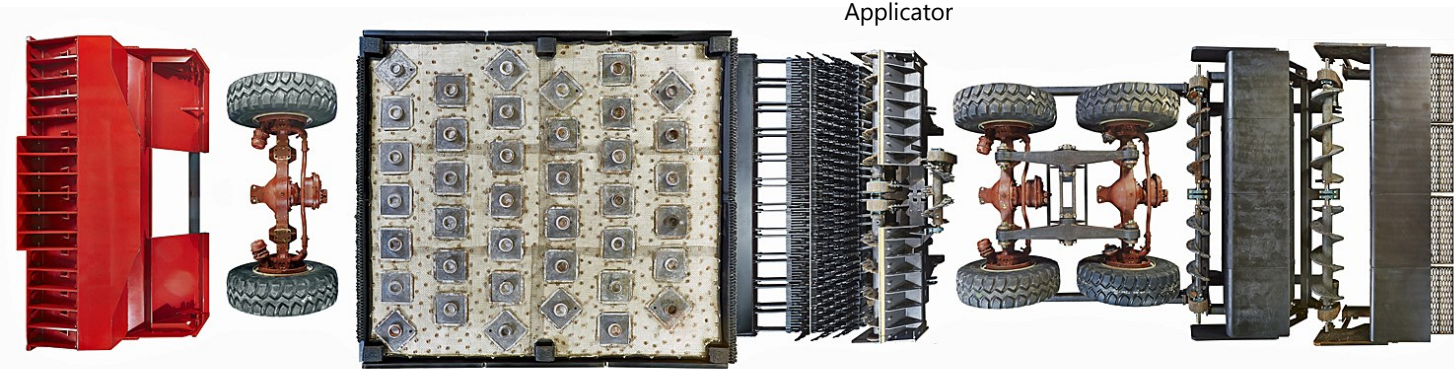

ROADWAY SELECTION GUIDELINE

Prior to the start of a REPAVING project, the following Pavement Distresses should be evaluated.

PAVEMENT DISTRESS	APPLICABILITY
SURFACE DEFECTS	
Raveling	Appropriate
Potholes	Appropriate
Bleeding (minimal)	Appropriate
Skid Resistance	Appropriate
DEFORMATIONS	
Shoulder Drop Off	No
Rutting – Wear	Appropriate
Rutting – Mix Instability (Note 1)	Possibly
Rutting – Deep Structural	No
Corrugations	Appropriate
Shoving (Note 1)	Possibly
LOAD ASSOCIATED CRACKING	
Fatigue – Bottom Up	No
Fatigue – Top Down, less than 1” wide (Note 2)	Appropriate
Edge (Note 3)	Appropriate
Slippage, if treatment exceeds slippage plane	Appropriate
NON-LOAD ASSOCIATED CRACKING	
Block, less than 1” wide	Appropriate
Longitudinal, less than 1” wide	Appropriate
Transverse, less than 1” wide	Appropriate
Reflective, less than 1” wide	Appropriate
COMBINED CRACKING	
Joint Reflection, less than 1” wide	Appropriate
Discontinuity, less than 1” wide	Appropriate
BASE/SUBGRADE DEFICIENCIES	
Swells, Bumps, Sags, Depressions (Note 4)	Not Likely
ROUGHNESS	
	Appropriate
OTHER	
All Levels of Traffic (Note 5)	Appropriate
Rural	Appropriate
Urban (Note 6)	Appropriate
Stripping (Note 7)	Possibly
Poor Drainage	No
Cross Slope Correction	Possibly
Existing PCI 40-65 (may vary)	Appropriate
Geotextile Fabric within 1” of HIR layer	No
Turning Radius greater than 500 feet	Appropriate
Install Safety Edge	Appropriate

NOTES

1. Mix instability in the surface could be cold milled or micro-milled prior to Repave process. Determine the severity and depth of existing layers that are affected.
2. Ensure structural requirements can be met.
3. May not correct but will mitigate. Provide shoulder confinement after HIR. Can be accomplished with a thickened edge.
4. Isolated areas could be repaired, full depth if need be, prior to HIR.
5. As long as proper pavement structural design is undertaken as part of the process to ensure the effects of future traffic are taken into account.
6. Edge milling at the concrete gutter lip may be required prior to HIR.
7. If stripping is confined to the lower layers of AC it could be left in place as asphalt treated base, if the HIR layer is not stripped.